

Fig.1: Manufacturing Techniques

Forming in the Mold:

Plates manufactured using the pressing process can be formed into a formed piece in a further process.

Formability tests have shown that good strengths are achieved with a forming temperature of 340°C or above. The various components were formed at a temperature of 360°C. U profiles and hat profiles manufactured in this way were used for producing the test structures for crash tests shown in Fig. 2.

Possible applications for aircraft parts manufactured in presses include spars, ribs and the skins of tailplanes. However, wing flaps or components for the aircraft interior, e.g. seats, are other areas of possible application.

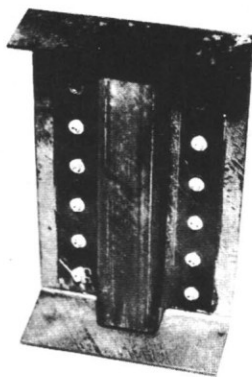
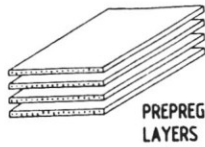

Fig. 2: Structure for Crash Tests

CF-PEEK ROCKER ARM

SINGLE PRODUCTION



CUTTING BY KNIFE

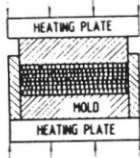

PRESSED IN HEATED MOLD
PRESSING CONDITIONS
TEMPERATURE: 383°C
PRESSURE: 5 bar
TIME: 5 MINUTES+WARM-THROUGH TIME

MACHINING BY
MILLING R/MIN 250
DRILLING R/MIN 200
GRINDING R/MIN LIKE STEEL

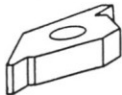
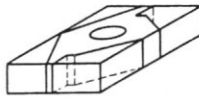

* COOLING WITH WATER
* TOOLS MADE OF HARD ALLOY
* DRILL WORKPIECE WITH SUPPORT
BONDING METAL PARTS IN PLACE

SERIES PRODUCTION

CUTTING BY
* WATERJET
* LASER
* ULTRASOUND

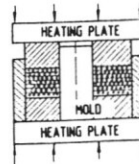

PRESSED IN HEATED MOLD
PRESSING CONDITIONS
TEMPERATURE: 383°C
PRESSURE: 5 bar
TIME: 5 MINUTES+WARM-THROUGH TIME

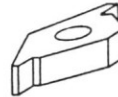

MACHINING
TRIMMING OF EDGES
BONDING METAL PARTS IN PLACE

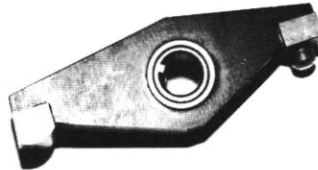

Fig. 3: Manufacturing Techniques for Rocker Arms

In addition to forming in a mold, ICI also recommends super plastic forming /2/, /3/. In such cases, however, the CF-PEEK material must be formed between Kapton foil or UPILEX foil, depending on the degree of forming. A forming temperature of 400°C is recommended for this process.

Rolling Process:

A rolling mill as shown in Fig. 1-D is suitable for welding reinforced thermoplastics into tapes and for forming reinforced thermoplastic tapes into profiles. However, due to the high processing temperature of PEEK and its low thermal conductivity, the required temperature cannot be achieved simply by heat transfer from the heated rollers in the roller gap without destroying the PEEK material at the contact point with the

rollers as a result of an excessively high temperature. A preheat area must be arranged before the rolling mill in such a way that the surface of the tape entering the gap between the rollers is cooled slightly in order to avoid it sticking to the roller, but so that the interior temperature of the tape is sufficiently high for processing or welding. The subsequent forming into a profile is made possible by a series of heated contour rollers.

Fig. 4 shows components made of CF-PEEK which were produced at the Institute in accordance with the process described above.

Reports have already been written on processes A, B and D /1/.

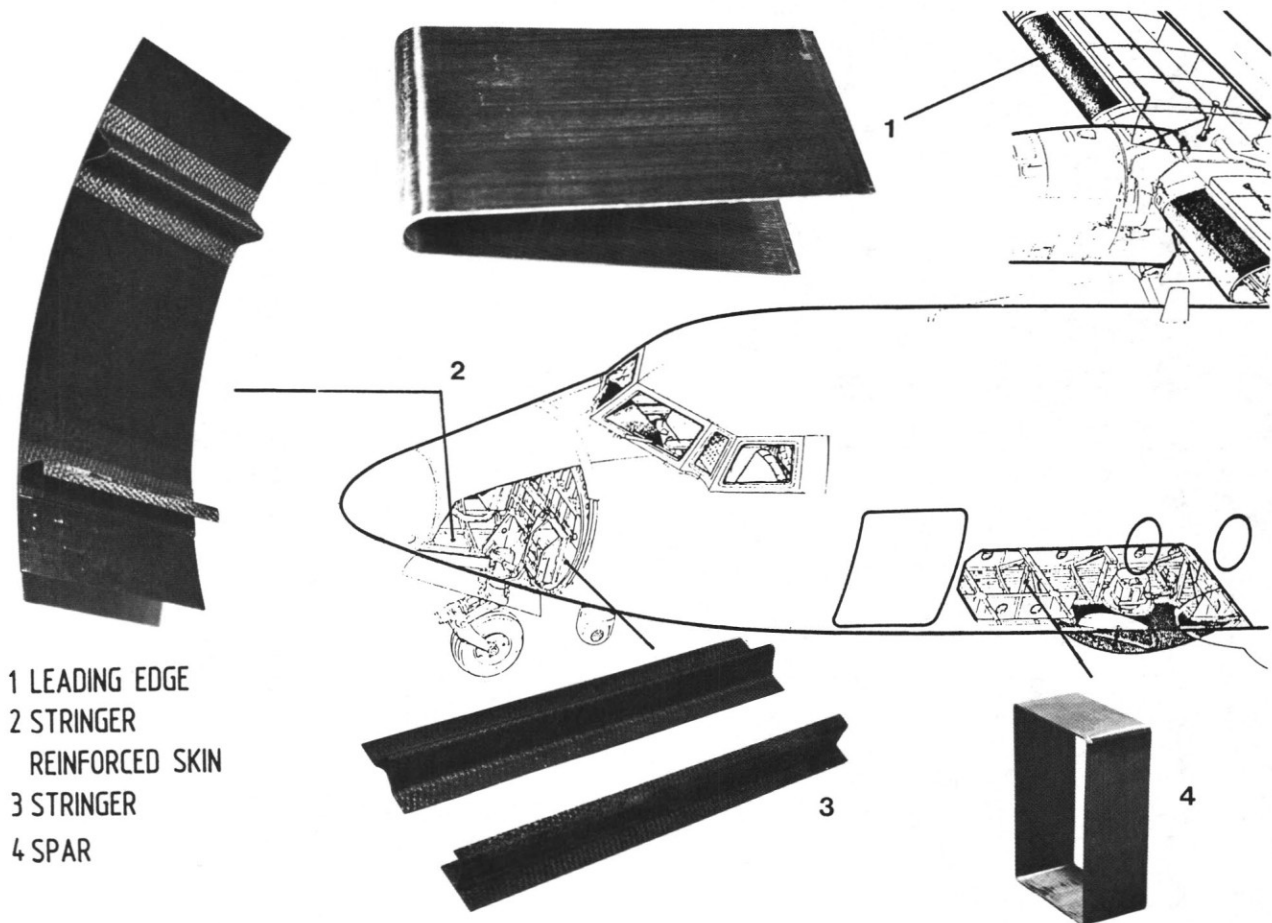

Fig. 4: Proposed CF-PEEK Structural Parts for Airplanes

Lay-up Process:

The method used to date for manufacturing components from continuous fiber reinforced thermoplastics involves the manufacture of flat plates which are then subsequently formed into structural elements, in some cases this is being done in several stages. Buckling of fibers often occurs in the corners during the forming process, thus reducing the load-bearing capacity.

When manufacturing larger components, extremely large presses have to be used because of the pressure required during the above-mentioned pressing process.

It was therefore necessary to develop a manufacturing process for formed parts made of continuous fiber reinforced thermoplastics which permits the simple manufacture of complicated formed parts with good strength properties.

The lay-up process shown in Fig. 1-C was thus developed, in which individual layers are placed one on top of the other on a heated mold. The next fiber layer is only added when the previous one has been fused on. If required,

the component can be further consolidated by the application of vacuum. This process makes it possible to produce components without the intermediary "flat plate" stage. In contrast to the components formed from flat plates, fiber orientation at the edges and narrow radii is maintained.

The lay-up procedure is shown in Fig. 5a. The prepreg layers are rolled onto a warmed mold face one after the other. The act of pressing on a continuous fiber reinforced layer onto a warmed mold face means that the layer is increasingly warmed from its underside. Here, it is important to note that the low thermal conductivity of thermoplastics leads to a temperature drop in the interior of the layer, i.e. the underside of the layer, which is facing the mold face, may already be softened while the upper side facing away from the mold face is still stable and non-adhesive. It is thus possible to achieve optimum matching of the layer to the mold by using a suitable tool, e.g. a roller. As the surface of the layer facing the mold face is soft, it easily adapts to the mold face, whereby even the fibers in the interior of the layer do not suffer any realignments during the forming process which would reduce its strength.

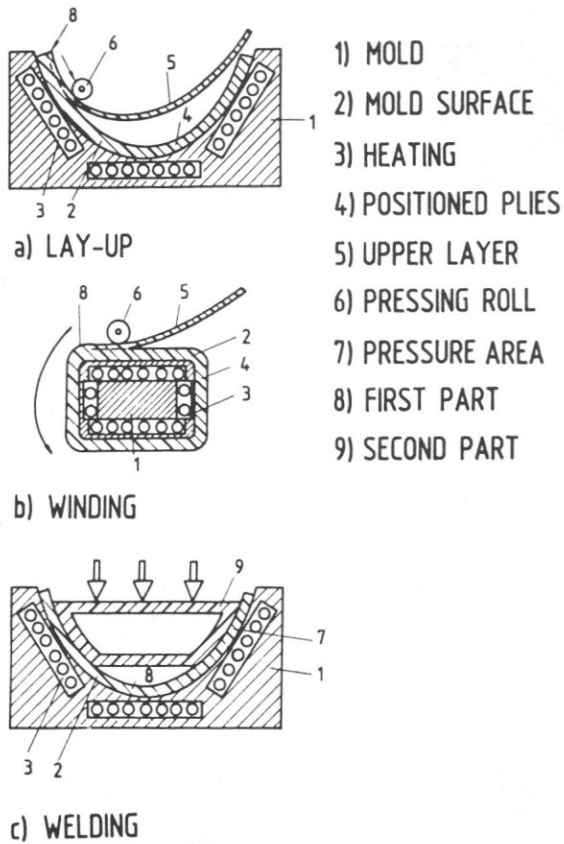

Fig. 5: In-House Developed Manufacturing Techniques

If the rollers are cooled, the layer can still be pressed onto the mold face when the temperature on the side of the layer facing away from the mold face is relatively high, as this can counteract the heating up and softening in the area affected. This is particularly advantageous when using very thin layers. In addition, the use of cooled rollers increases the period of time in which the layer can be pressed on without any adhesion of the material occurring.

Pressing the layer to the mold improves the heat transfer and thus accelerates the softening process in the region close to the mold whereas the temperature on the outside continues to increase slowly, particularly with cooled rollers. A heated mold is shown in Fig. 6, while Fig. 7 shows a component manufactured on this mold in accordance with the process described above.

Tests with a CNC device for depositing layers have shown that the lay-up process can also be automatized (Fig. 8).

Furthermore, the molded part can be consolidated - either by the application of vacuum or in an autoclave - after laying the plies of the continuous fiber reinforced plastic. This improves the overall quality of the molded part.

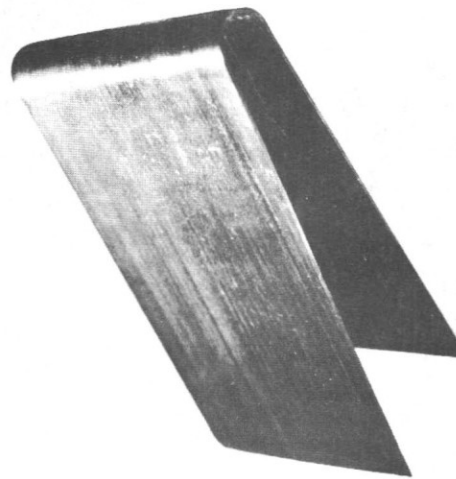

Fig. 6: Leading Edge

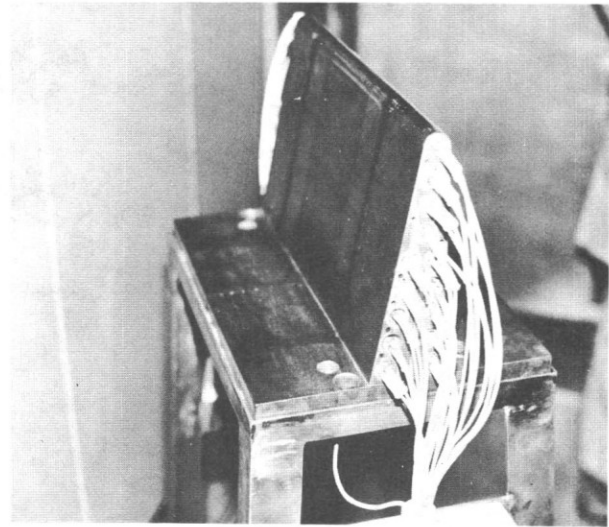

Fig. 7: Mold for Leading Edge

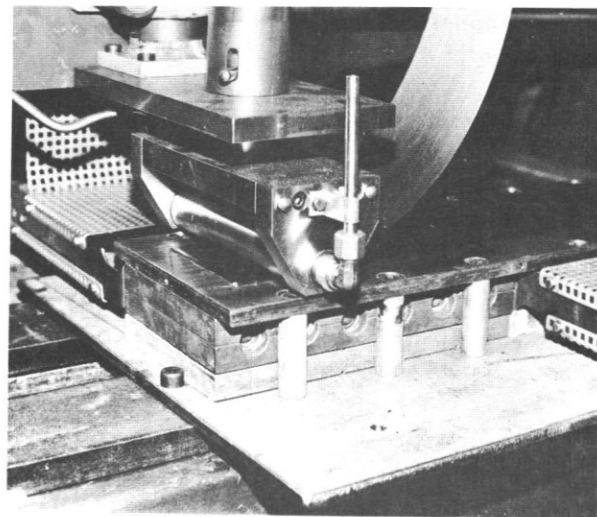

Fig. 8: Automatized Lay-Up

The experience gained from the process described above led to a winding process being developed (Fig. 5b), in which the layers are wound one after the other onto a mold in the form of a winding core. In all other respects, the technique applied is the same. This makes it possible to produce a hollow part from which the winding core can be removed in the axial direction once it has cooled down. The speed selected is such that the layer is heated right through before the next layer is applied. Pipes and spars were manufactured in accordance with this process (Fig. 9).

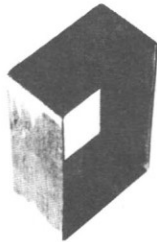

Fig. 9: Spar-Segment

The low heat conductivity of PEEK was used for welding tests. One of the parts is heated to the required welding temperature (383° - 400°C) and a cold or pre-heated second part pressed on to this (Fig. 5c). The contact area is welded without the second part losing its stability (Fig. 4, part 2). This can be achieved by reducing the temperature of the first part or cooling down once the second piece has been pressed on. In the case of components with large surface areas, the temperature can be reduced very effectively by individually adjustable heating elements. The welding quality can be improved by applying an intermediate layer of PEEK foil

The lay-up procedure cannot be compared with conventional process methods. Its most important features are:

- * Heat is introduced from one direction.
- * The individual layers can be processed without release agents.
- * Wall thicknesses of up to approx. 5 mm can be achieved.
- * Presses are not required.
- * Fiber orientation is maintained even with small radii.
- * The procedure can be controlled.
- * The rigid prepreg can be placed in curved molds without any preliminary damage occurring.

It is, however, also possible to manufacture molded parts in accordance with the lay-up process and using a press mold to join these parts into a profile part such as a stringer (Fig. 10).

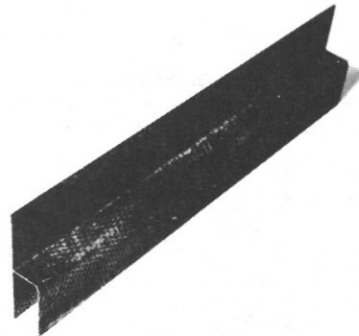

Fig. 10: Stringer

A variation of the lay-up process C can also be used to manufacture larger plates or larger components which are only slightly curved.

The layers are placed on a heatable mold face in accordance with the intended structure. These are then covered with an aluminium foil. Vacuum is then applied and the mold face heated to 390° - 400°C. After this temperature has been reached it is necessary to wait 1 minute per layer before a roller is rolled over the aluminium foil in order to smooth the surface. The heating is then switched off and the system cooled down.

III. Tests

In order to compare the production quality of the different processes, plates were manufactured in accordance with the following processes:

Type of manufacture		After-treatment
B	Pressing in a mold	None
C1a	Lay-up process (manual)	None
C1b	Lay-up process (manual)	Post compaction in vacuum
C2	Lay-up process (automatized)	None
C3	Consolidated in vacuum	None

The following tests were conducted with specimens cut from these plates:

- * Short beam tests between -40°C and +140°C
- * Transverse bending tests between -40°C and +140°C

Short beam tests and transverse bending tests are particularly suitable for examination of the production quality of fibrous composite materials.

Thermal decomposition was also examined with the aid of thermogravimetric experiments and lap shear tests.

Short Beam Tests

As expected, failure stress falls as temperature increases. This applies to all types of processing. The results are shown in Fig. 11. In order to be able to make a qualitative comparison, the specimen which was pressed in the mold - process B - and which is taken to be the standard specimen, had a failure stress of 104 N/mm² at room temperature and was defined as representing 100% (Fig. 12). The comparison shows that the specimen assembled by hand - process C1a - produced the lowest result of 86%. Part of this specimen, C1b, which was further consolidated in vacuum, produced a result of 99%. C2, the specimen assembled automatically, achieved 92% of the comparative value without post-compaction in vacuum. C3, the specimen produced directly in vacuum - process derived from process C -, shows values higher than the average values for the comparative specimen but which still lie in the scatter range of the specimens from process B.

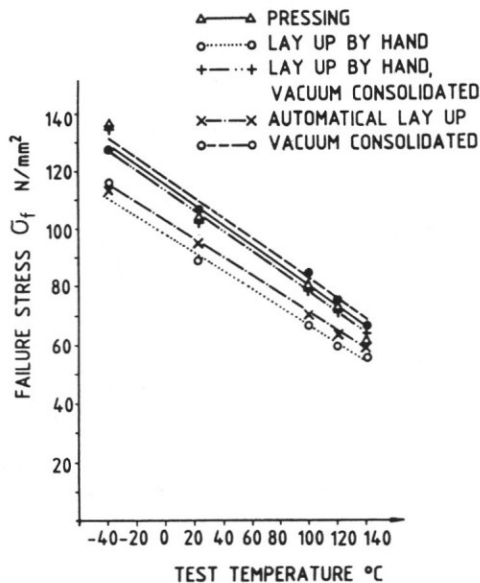
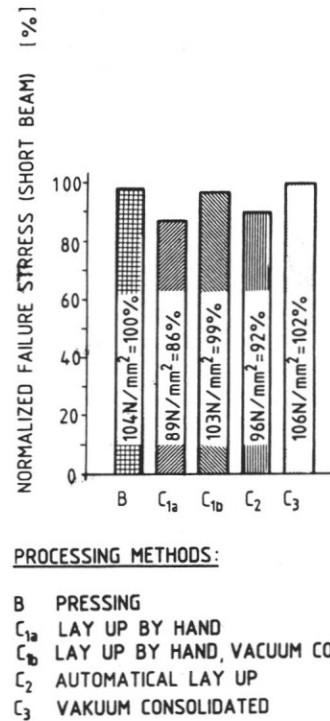

Fig. 11: Short Beam Test Results



PROCESSING METHODS:

- B PRESSING
- C1a LAY UP BY HAND
- C1b LAY UP BY HAND, VACUUM CONSOLIDATED
- C2 AUTOMATICAL LAY UP
- C3 VACUUM CONSOLIDATED

Fig. 12: Influence of Processing Methods Short Beam Test Results

An explanation for the different strengths can be found by looking at the micrographs (Fig. 13a-e). In specimens produced according to C1a, voids can be seen, as shown in Fig. 13b. No voids are visible in the specimens produced according to pressing process B (Fig. 13a).

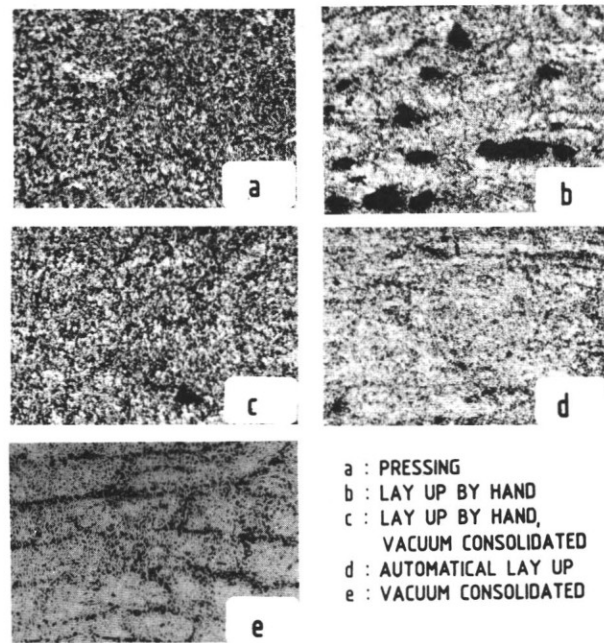

- a : PRESSING
- b : LAY UP BY HAND
- c : LAY UP BY HAND, VACUUM CONSOLIDATED
- d : AUTOMATICAL LAY UP
- e : VACUUM CONSOLIDATED

Fig. 13: Micrographs (50 x)

The unevenness of the APC2 prepreg cannot be smoothed out in the manual lay-up process. However, it is expected that prepregs with a smoother surface will be available in future so that it will also be possible to produce a laminate with fewer voids and correspondingly improved strength characteristics when using the manual lay-up process. These defects can be reduced by post-compaction in vacuum, as shown in Fig. 13c, or can be kept as low as possible by the automatical lay-up process, C2, as shown in Fig. 13d. The specimens obtained from process C3 are also without voids (Fig. 13e).

The fiber content of the tested specimens showed a maximum difference of 3%. These small differences cannot be responsible for the different strength values.

Transverse Bending Test

As with the short beam test above, the failure stress also decreases as the temperature increases during the transverse bending test. Measurements were taken in the range from -40°C to +140°C (Fig. 14). Once again, the specimen which was pressed in the mold was used for the qualitative comparison and the failure stress of 133 N/mm² at room temperature was defined as representing 100% (Fig. 15). It can be seen that the value of the manually assembled specimen is 56% and lies below the values of the other specimens. This is because, as already mentioned in the section on short beam tests, voids are present which can be removed or reduced by consolidation in vacuum. This is also confirmed by specimen C1b which has a value of 95%. A further reason for the poor result of 56% is a notch effect produced because the surface is not totally smooth.

In the case of the material assembled mechanically, this surface was improved because of the higher contact pressure produced by the roller. Production quality is considerably increased by automatical assembly, not only because of the improvement to the surface, but also because of the constant conditions which cannot be ensured by manual assembly. The value of 91% achieved by the automatically assembled specimen without consolidation in vacuum is a good result. The quality of the specimen consolidated in vacuum also proved very good in the transverse bending test, reaching a value of 98% being achieved. However, as mentioned above, this process can only be used for flat or slightly curved parts.

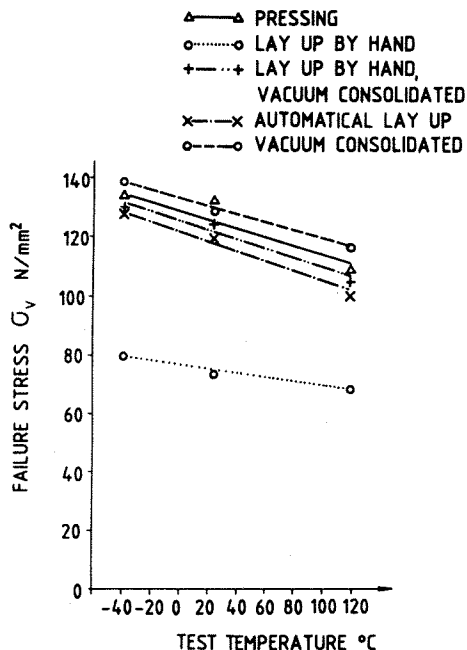

Fig. 14: Transverse Bending Test Results

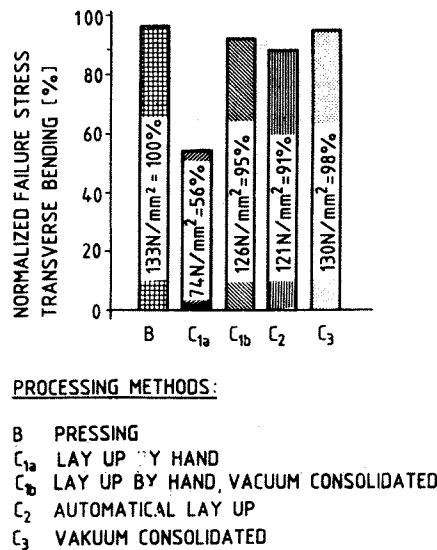

Fig. 15: Influence of Processing Methods Transverse Bending Test Results

Thermal Decomposition

During process C, the PEEK remains at the processing temperature for a longer time, particularly when larger components are being processed. In order to be able to determine the degree of any possible thermal decomposition, both the weight loss of PEEK granules and the strength of specimens subjected to thermal loads were measured.

The Mettler TA 3000 thermoanalysis system was used for the thermogravimetric test. Type 380G PEEK granules were dried for 12 hours at 150°C in an air circulating oven and were then placed immediately in the microbalance of the Mettler system. Weight loss was measured after 1 hour and after 3 hours at different temperatures in air and in the inert gas argon.

The following weight losses were recorded:

In air	at 380°C	after 1 hr: 0.13%,
		after 3 hrs 0.34%
	at 400°C	after 1 hr: 0.25%,
		after 3 hrs 0.73%
	at 420°C	after 1 hr: 0.44%,
		after 3 hrs 1.25%

In argon	at 380°C	after 1 hr: 0.07%,
		after 3 hrs 0.16%
	at 400°C	after 1 hr: 0.07%,
		after 3 hrs 0.17%
	at 420°C	after 1 hr: 0.15%,
		after 3 hrs 0.38%

After 3 hours in air at 380°C, the grey color of the granules had turned to medium brown, and at 420°C to dark brown. After 3 hours in argon at 380°C, the color had changed to light brown and at 420°C to medium brown.

Weight loss and discoloration increase as temperature and time increase and are less pronounced in argon than in air. Double lap joint specimens were produced for performing further investigations into the question of thermal decomposition. The comparative specimens were produced without thermal load in a mold and achieved a shear strength of 50 N/mm²/4/. In the case of the specimens subjected to thermal load, the connecting surfaces of the double lap joint were exposed to air at 400°C for different time intervals before being pressed in the mold. After 3 hours' thermal load, the shear strength was only 25% of the original strength. After 15 minutes' thermal load no reduction in strength was observed. This corresponds to ICI data /5/.

Thermal decomposition can be avoided under the processing conditions and processes specified above. During processing using the pressing process, all surfaces with the exception of the front faces are covered. For the lay-up process and the roller process it is possible to add or form the next layer within a period of 15 minutes. A safe processing time of approx. 15 minutes at 400°C in air would correspond to a component of approx. 0.5 m² (conditions: 1 tape laying head, tape width 10 cm). If several tape laying heads are used together with wider tapes and possible pre-heating of the tapes, it is possible to produce larger components.

IV Conclusion

The test results show that, according to the structure in question, the following processes:

- * Pressing in a mold using film and fiber lay-up
- * Pressing in a mold using prepregs
- * Lay-up process using separate prepreg layers
- * Rolling process using prepreg tapes

are also suitable for the manufacture of larger numbers of items. The voids observed in some manufacturing techniques may be reduced by increasing prepreg quality.

The pressing process and the forming process referred to above can be used for many applications. Thermal decomposition of the matrix does not occur under the pressing conditions specified above.

The roller process is a continuous process. When manufacturing tapes and profiles the residence time of the PEEK material at the processing temperature is extremely short and no thermal decomposition should thus occur.

For the lay-up process, the possibility of using a CNC device for depositing layers means that any type of layer structure and any size of component are possible.

V. References

- /1/ G. Kempe Processing and Mechanical Properties of Fiber-Reinforced Polyetheretherketone (PEEK) ICAS-84-3.1.1 Toulouse/F Sept. 1984
- /2/ A.J. Barnes Advances in Thermoplastic Composite Fabrication Technology 2nd MEI Conference London/UK, Nov. 1985
- /3/ I.B.Cattanach Processing with Aromatic Polymer Composites Developments in Reinforced Plastics, Vol. 1, Pitchard, G.(Ed), Elsevier Pub. 1986
- /4/ W. Krenkel Evaluation of Welded and Adhesive Bonded Carbon-fiber Reinforced PEEK Comp'86, Int. Symp. on "Engineering Applications of New Composites" Patras/Gr, 1986
- /5/ F.N.Cogswell Personal Communication